

GEN2®

Designed for a world in motion

OTIS



Set your building apart

Whether helping busy commuters get to work or delighting people as they shop, your building should be a unique experience for anyone who steps inside. The Gen2 elevator system has the style, comfort and speed needed to ensure passengers experience your building to the fullest. With space-saving architectural features that maximize design freedom, Otis helps your building stand out.

OTIS GEN2 OVERVIEW

| Description | Machine room-less | Machine room |
|---------------|-------------------|---------------|
| Speed | 1.0 – 3.5 m/s | 1.0 – 2.5 m/s |
| Capacity | 630 – 2000 kg | 630 – 2000 kg |
| Maximum stops | 50 | 50 |
| Maximum rise | 150 m | 140 m |



Design without limits

Gen2 technology is sized to fit inside the wall of the top elevator landing – eliminating the need for a control room. So whether you want to impress visitors with an expansive, seamless lobby or offer tenants a larger space, Gen2 gives you the room to bring your vision to life.



COMPACT DESIGN

Gen2 technology eliminates machine room space and cost for greater architectural design freedom.



COMPACT CONTROLLER

Sized to fit inside the wall or in the door lintel of the top elevator landing, the controller can be accessed by an attractive, concealed test panel.



MAXIMIZED SPACE SAVINGS

Flexible coated steel belts allow a smaller machine sheave, reducing machine size by 80% and raising efficiency up to 50%.

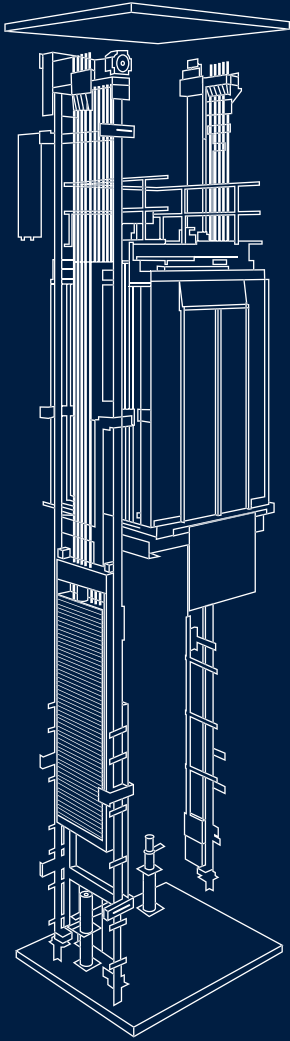

MACHINE ROOM-LESS CONFIGURATION

With the machine room-less configuration of the Gen2 elevator, all you need is a hoistway. The machine and controller are so compact, they fit inside the hoistway. No need for an extra room on top of your building for elevator components. You save on construction costs and clear rooftop space.

COMPACT MACHINE ROOM CONFIGURATION

The compact machine configuration reduces the space requirements for the Gen2 elevator to no larger than the hoistway footprint, reducing construction costs and optimizing rooftop space.

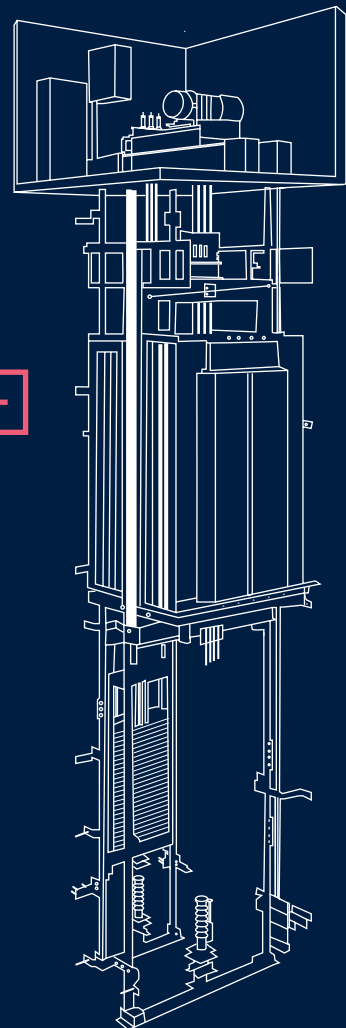

HOISTWAY SPACE

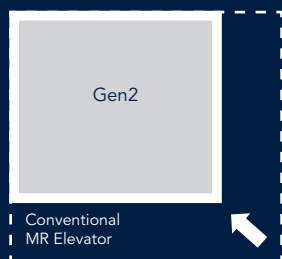

MACHINE ROOM HEIGHT

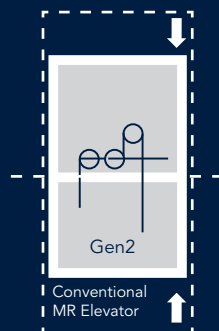

Limitless design possibilities

From modern to natural ambiances, Gen2 can be tailored to fit your architectural vision. Textures, classic materials and fittings offer virtually unlimited design flexibility for creating an inviting experience. Explore more than 400,000 options by visiting the online Otis cab configuration tool at cabcreate.otis.com.



NATURAL AMBIANCE

Wood, stone and leather materials create new-age designs inspired by architectural movements. This approach features smooth accents as seen in rounded corners, handrails and optional matching ceiling lights.

| | |
|-----------------|--------------------------------------------------------------------------------|
| STANDARD | Imitation wood, stone and leather |
| ADVANCED | Wood and concrete laminates |
| PREMIUM | Exotic wood laminates for side panels and glossy baked enamels for rear panels |



MODERN AMBIANCE

Timeless design is blended with modern materials to create a hi-tech experience. Sharp forms enhance metallic and glossy textures. Dark anodized decorative elements contrast with vertical lighting.

| | |
|-----------------|---------------------------------------------------------------------------------|
| STANDARD | Imitation metal, stone and concrete |
| ADVANCED | Unique metal and stone laminates |
| PREMIUM | Exotic metal laminates for side panels and glossy baked enamels for rear panels |

OTIS

630 kg 8 PERS
CE0041 781V5558 2016

GLARE-FREE LIGHTING

Indirect light from car corners and control panels creates a comfortable environment for passengers.



A smarter way to move throughout your day

Even short moments of waiting can feel like a lifetime. Otis reimagined how to navigate seamlessly through your building. With CompassPlus destination dispatch, we put personalised technology at your passengers' fingertips. CompassPlus creates an upscale, concierge-like experience that keeps everyone on the move.



IMPROVED TRAFFIC

SmartGrouping organises people to get them to their destinations up to 50 percent faster than conventional dispatching, while making minimal stops. This system adjusts dynamically based on your building's needs throughout the day.



INTUITIVE DESIGN

Our CompassCreate™ software provides an array of eye-catching screen options that intuitively navigate people throughout the building.





SMARTPHONE ACCESS

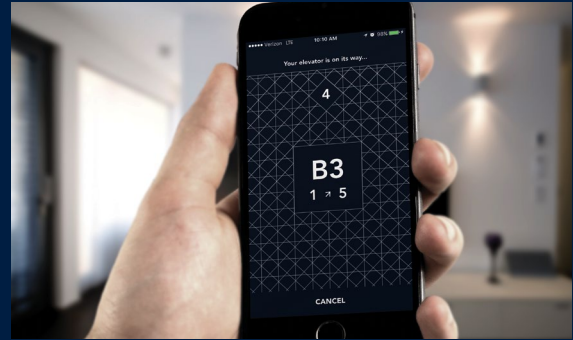

Call your elevator even before you get to the elevator bank with the eCall smartphone app.

SECURITY



eCall can be integrated with any third-party building security system and accommodates both external and built-in security ID readers.

CUSTOMISATION



Personalise your passenger experience with custom messages – shown hourly, daily, weekly or for special occasions. And complement your building's style with buttons, colors, fonts and imagery of your choice.

Fingertip control

Whether your passengers are regular visitors or new to the building, with the help of CompassPlus they'll find it easy and effortless to get to the right location quickly.

VIA THE WALL-MOUNTED SCREEN

01

ENTER DESTINATION



02

RECEIVE ELEVATOR ASSIGNMENT



03

PROCEED TO ASSIGNED ELEVATOR



From hotels to hospitals...

CompassPlus brings the concept of high-performance destination dispatching to a much wider range of environments, including low-rise buildings. The three generations of Compass are now installed in over 10,000 elevators, 300 cities and 60 countries.



COMPASSPLUS IS THE PERFECT SOLUTION FOR...

- Commercial buildings
- Hotels
- Mixed-use locations, including sporting venues and shopping malls
- Residential real estate
- Hospitals

Please note that the results mentioned may vary in each installation.



Change the look and feel

With a wide range of presentation styles to choose from, CompassPlus coordinates with your design vision and fits neatly into the fabric of your building.

ON-SCREEN DISPLAYS

Choose from five off-the-shelf design templates for your user interface screens, with 12 options for background color schemes, as well as a unique library of icons.

FIXTURES

There are two CompassPlus fixture options: a 7" touchpad and a 12" touchscreen. Both formats are available in four different color schemes: black, white, silver and gold.

WAYFINDING SIGNS

Eye-catching and easy to follow, with built-in chimes, our suite of wayfinding signage includes unlit static and white-light dynamic options, as well as four color choices. Rotate the back plate to mount the signs horizontally or vertically, enabling easy replacement of old horizontal hall position indicators or vertical hall lanterns in modernization projects.

CUSTOMIZED DESIGN

Prefer to create your own look for your interface screens to match the style of your building or your corporate brand? You can customize a range of features, including colors, fonts, icons and images.

Your comfort is our focus

We sharpened our focus on speed and performance without compromising comfort. We reduced metal-on-metal contact and dampened vibrations to ensure the Gen2 ride is smooth and quiet.



SWIFT MOVEMENT

High-performance door operators and superior car acceleration allow passengers to enter and exit elevators more quickly.



SMOOTH COATED STEEL BELTS

The steel belts eliminate the noise created by the metal-on-metal contact from conventional steel ropes.



LOW-NOISE GEARLESS MACHINE

Mounted on isolation rubber pads, the low-noise gearless machine reduces vibration and minimizes noise in adjacent rooms.





Reliable, as expected

Some of the world's most distinguished buildings trust in Gen2 technology. Manufactured exclusively at our ISO-certified factories, the Gen2 system is the result of our most advanced thinking, global experience and deep engineering expertise. All so you can be sure of getting exceptional Otis performance day after day.



PULSE

The Pulse System continuously monitors the elevator's coated steel belts to safeguard their integrity, ensuring safe, efficient operation and reduced inspection downtime.



AUTOMATIC RESCUE OPERATION

Battery-powered systems deliver passengers safely to the nearest floor during a power failure.



ENHANCED SEISMIC PROTECTION

Coated steel belts and a uniquely designed machine sheave work together to provide greater stability during seismic activity.



'MADE IN OTIS'

Every country in which we operate must meet or exceed the Otis standard. The Passport System requires each product to move through a series of meticulous inspections during its development. Once approved by a team of experts, the product moves on to its next stage. Otis champions UTC's overarching process of Achieving Competitive Excellence (ACE). Every factory, wherever its location, has an entire workforce committed to this high standard of manufacturing.

Create a lasting experience

Whatever your sustainability goals – from designing net-zero buildings to managing your energy efficiency – Gen2 is engineered to meet your needs.

+ **REGEN™ DRIVE**

75%

more efficient than conventional geared systems with non-regenerative drives, while providing clean power to help run other building systems.

+ **LED LIGHTING**

10x

longer lifespan of Gen2 LED lighting compared to conventional fluorescent lamps.



LUBRICATION

ZERO

coated steel belt and machine lubrication needed, providing for a cleaner hoistway and elevator environment.



SLEEP MODE

75%

more efficient LED energy usage with sleep mode – lights and fans shut down when not in use and are automatically restarted with the touch of a button.

We're with you from concept to completion

Creating a unique experience for tenants and customers takes a lot of thought, planning and coordination. Thankfully, you don't have to do it alone. For over 160 years, we've helped customers all around the world reach new heights while helping billions of passengers arrive at their destinations every day. So from detailed project planning to ongoing service, we're here to help you every step of the way.



PROJECT DESIGN

We consider architectural solutions, traffic analysis, product specifications and value engineering to help craft and deliver on your vision.



SPECIALIZED INSTALLATION PLANNING

Our team helps at every step of the installation process, from coordinating contractors to monitoring specialized safety reviews to delivering a smooth handover when the project is complete.



A commitment to exceptional service

We know what it takes to keep people moving safely and smoothly. Our founders were dedicated to delivering extraordinary service, and today we're continuing that promise with personalized and imaginative ways to meet our customers' every need.

Benefit from the industry's leading service offering, featuring 24/7 dedicated customer support through OTISLINE[®], more intuitive access to information with the eService customer portal and our personal commitment to always put your needs first.



**Signature
Service**



WE EARN YOUR TRUST — EVERY DAY

Our mechanics see your building as their own. With a global team of more than 30,000, we work around the clock to keep your equipment operating like new. The result is truly personalized service that ensures we build your trust over the lifetime of your equipment.



TURNING DATA INTO ACTION

As one of the first elevator companies to use big data and predictive analytics to improve performance, we're experts at getting the most out of emerging technology. Our digital ecosystem uses the "internet of things" and mobility tools to predict and diagnose issues before they occur. All this to stay ahead of your needs and to deliver a personalized passenger experience.

Standard equipment

TRACTION

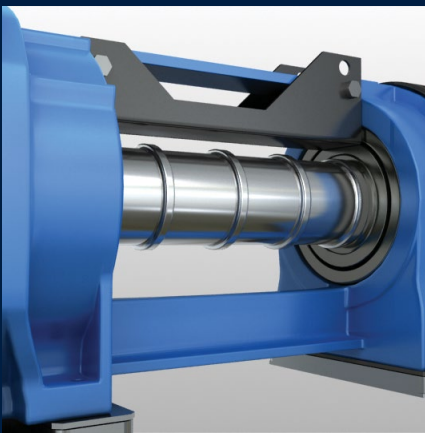

- Gearless machine with synchronous permanent magnet motor
- Radial low inertia design
- 240 starts/hour in peak abilities

MONITORING



- Automated rescue operation
- Pulse 24/7 belt integrity monitoring system
- Two-way communication and remote intervention system with cellular 3G option

ROPING



- 2:1 overslung configuration
- All moving elements integrated in the top of the high-resistance steel frame in charge of absorbing mechanical constraints

CONTROL & POWER

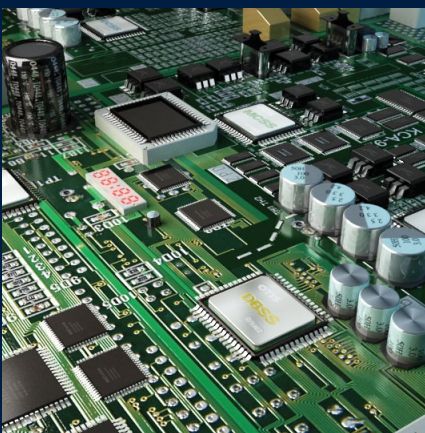

- Modular microprocessor system
- Closed loop, variable frequency and voltage
- Regenerative drive with +/- 3 mm stopping accuracy
- Standby mode
- LED lightning in car and for hall fixtures

SUSPENSION

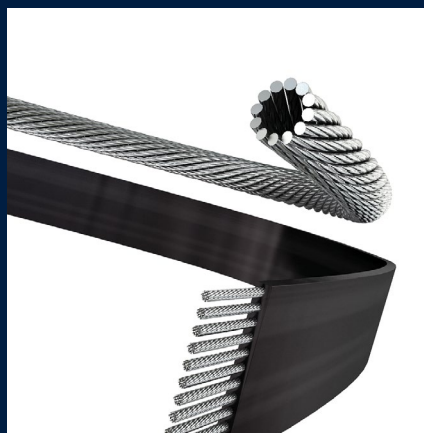

- Stainless steel polyurethane-coated belts instead of conventional ropes
- Lubrication free
- Life duration twice as long as conventional ropes

DOORS



- Variable speed high-traffic door operator 240 stats/hours in peak
- EN81-58 fire resistant
- Reinforced self-cleaning slotted sill and aluminum door track with protected roller system
- Car door lock compatible

Main options

PANORAMIC



- Full glass car
- Full glass hoistways
- Compatible with outside installation for infrastructure projects

DOORS



- Landing or hoistway installation
- Full frame, small frame or no frame options
- Glass or full glass

HALL FIXTURES



- Flat or flush mounting
- In-car lintel or wall mounting
- Brushed, mirror or gold stainless steel finishes

PREMIUM RIDE QUALITY

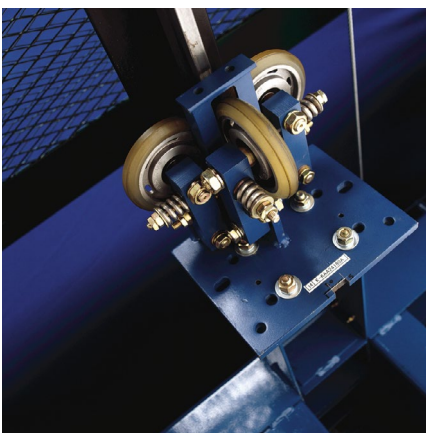

- High-speed friction rollers with compensating bumpers
- A class rails
- Reinforced rails attachments
- Down to 50 dB(A) noise and 10 milli-g vibrations in car

CAB AESTHETICS

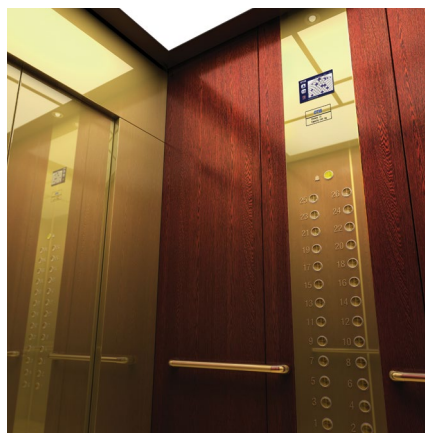

- Ambiance aesthetics – thousands of combinations available in natural and modern styles
- Modular aesthetics – a large range of preset styles to suit your building

FULL CUSTOMIZATION



- Variable dimensions
- Special car lining and doors
- High-constraint environment
- Our team stays at your disposal to make your project possible

Gen2 Machine room-less specifications (1 - 2.5 m/s)

| Duty load (kg) | Speed (m/s) | K Minimum (mm) EN81-1 | K Minimum (mm) EN81-20 | S Minimum (mm) EN81-20 | Maximum number of stops | Maximum rise (m) | Cars in a group |
|----------------|-------------|-----------------------|------------------------|------------------------|-------------------------|------------------|-----------------|
| 630<=DL<=1000 | 1 | 3759 | 4159 | 1229 | 20 | 50 | Up to 8 |
| | 1.5 | 3907 | 4307 | 1331 | 31 | 80 | |
| | 1.6 | 3917 | 4317 | 1331 | 35 | 90 | |
| | 1.75 | 3979 | 4379 | 1375 | 37 | 96 | |
| | 2 | 4137 | 4537 | 1671 | 47 | 120 | |
| | 2.5 | 4372 | 4772 | 1827 | 47 | 120 | |
| 1150<=DL<=1600 | 1 | 3775 | 4191 | 1249 | 20 | 50 | |
| | 1.5 | 3923 | 4339 | 1351 | 31 | 80 | |
| | 1.6 | 3933 | 4349 | 1351 | 35 | 90 | |
| | 1.75 | 3995 | 4411 | 1395 | 37 | 96 | |
| 1150<=DL<=1275 | 2 | 4137 | 4587 | 1691 | 43 | 110 | |
| | 2.5 | 4372 | 4822 | 1847 | 45 | 115 | |
| 1350<=DL<=1600 | 2 | 4137 | 4587 | 1691 | 47 | 120 | |
| | 2.5 | 4372 | 4822 | 1847 | 47 | 120 | |
| 1800<=DL<=2000 | 1 | 3873 | 4273 | 1195 | 20 | 50 | |
| | 1.5 | 4020 | 4420 | 1298 | 31 | 80 | |
| | 1.6 | 4031 | 4431 | 1298 | 35 | 90 | |
| | 1.75 | 4093 | 4493 | 1342 | 37 | 96 | |
| | 2 | 4189 | 4589 | 1402 | 47 | 120 | |
| | 2.5 | 4424 | 4824 | 1683 | 47 | 120 | |

| Duty load (kg) | Speed (m/s) | Car dimension (mm) | | (OP) x (OPH) (mm) | (HW) x (HD) (mm) |
|----------------|--------------|--------------------|-------------|-------------------|------------------|
| | | (CW) x (CD) | Height | | |
| 630 | 1.0 - 1.75 | 1100 x 1400 | 2300 | 800 x 2100 | 1820 x 1750 |
| 680 | | 1150 x 1400 | | | 1850 x 1750 |
| 750 | | 1300 x 1400 | | | 1940 x 1750 |
| 800 | 1.0<=V<=1.75 | 1350 x 1400 | | 800 x 2100 | 2000 x 1750 |
| | 2.0<=V<=2.5 | | | | |
| 1000 | 1.0<=V<=1.75 | 1600 x 1400 | | 900 x 2100 | 2230 x 1750 |
| | 2.0<=V<=2.5 | | | | |
| 1000 | 1.0<=V<=1.75 | 1100 x 2100 | | 900 x 2100 | 1950 x 2450 |
| | 2.0<=V<=2.5 | | | | |
| 1150 | 1.0<=V<=1.75 | 1800 x 1450 | | 1000 x 2100 | 2500 x 1800 |
| | 2.0<=V<=2.5 | | 2550 x 1800 | | |
| 1275 | 1.0<=V<=1.75 | 1950 x 1450 | 1100 x 2100 | 2660 x 1800 | |
| | 2.0<=V<=2.5 | | | 2700 x 1800 | |
| 1350 | 1.0<=V<=1.75 | 2000 x 1500 | 1100 x 2100 | 2710 x 1850 | |
| | 2.0<=V<=2.5 | | | 2750 x 1850 | |
| 1600 | 1.0<=V<=2.5 | 2000 x 1700 | 1100 x 2100 | 2710 x 2050 | |
| | 2.0<=V<=2.5 | | | | |
| 1800 | 1.0<=V<=2.5 | 1900 x 2000 | 1100 x 2100 | 2630 x 2330 | |
| 2000 | 1.0<=V<=2.5 | 2000 x 2000 | 1100 x 2100 | 2730 x 2330 | |

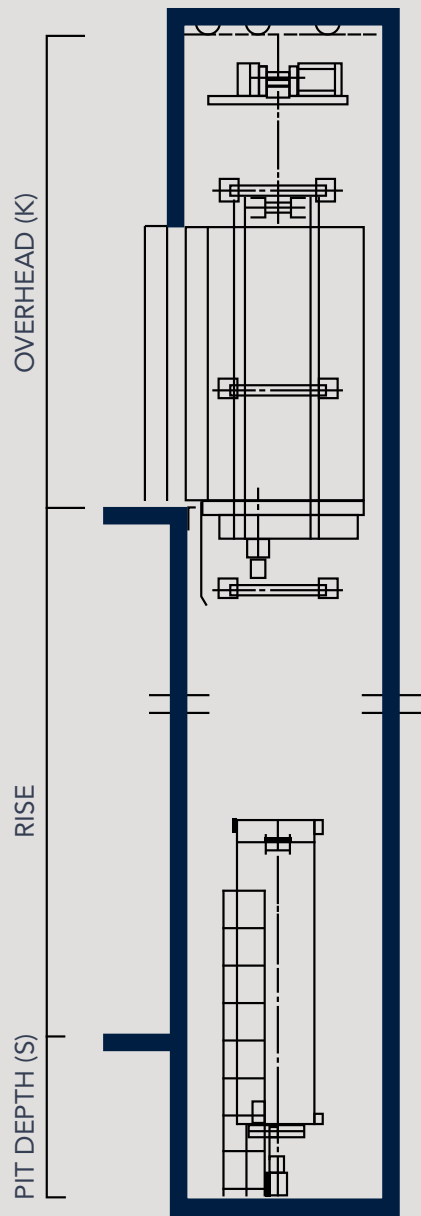

ELEVATION

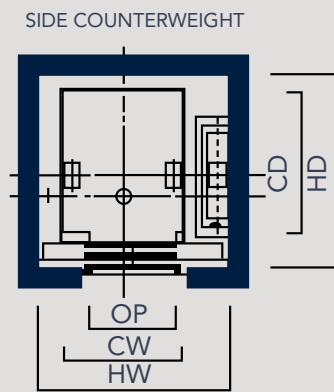

HOISTWAY PLAN

Gen2 Machine room-less specifications (3 - 3.5 m/s)

| Duty load | | 900 | | 1000 | | | | 1275 | | | | 1600 | | | | | | |
|----------------------------------------|----------------------|-------------------------------------|---------------------------|----------------------------------|---------------------------|----------------------------------|---------------------------|----------------------------------|---------------------------|----------------------------------|---------------------------|----------------------------------|---------------------------|----------------------------------|---------------------------|----------------------------------|---------------------------|--|
| Passenger capacity | | 12 | | 13 | | | | 17 | | | | 21 | | | | | | |
| Size | | Wide | | Deep | | Wide | | Deep | | Wide | | Deep | | Wide | | | | |
| Number of entrances | | 1 | | | | | | | | | | | | | | | | |
| Speed (m/s) | | 3 | | | | | | | | | | | | | | | | |
| Counterweight safeties | | Without | With | Without | With | Without | With | Without | With | Without | With | Without | With | Without | With | Without | With | |
| Hoistway dimension (mm) | Width (HW) | 2180 (CLD900) | 2300 (CLD900) | 1930 (CLD800) | 2050 (CLD800) | 2300 (CLD900) | 2430 (CLD900) | 1900 (TLD1000) | 2030 (TLD1000) | 2700 | 2830 | 2310 | 2310 | 2700 | 2830 | 2800 | 2930 | |
| | | 2100 (TLD900) | 2230 (TLD900) | 2030 (CLD900) | 2150 (CLD900) | 2380 (CLD1000) | 2500 (CLD1000) | 2010 (TLD1100) | 2030 (TLD1100) | | | | | | | | | |
| | | | | 1800 (TLD900) | 1930 (TLD900) | 2480 (CLD1100) | 2600 (CLD1100) | | | | | | | | | | | |
| | | | | 1860 (TLD1000) | 1930 (TLD1000) | | | | | | | | | | | | | |
| Depth (HD) | | 1800 (CLD) | 2060 (CLD) | 2400 (CLD) | 2460 (CLD) | 1750 (CLD) | 2010 (CLD) | 2690 (TLD) | | 1750 | 2010 | 2790 | 2790 | 2000 | 2260 | 1900 | 2110 | |
| | | 1890 (TLD) | 2110 (TLD) | 2490 (TLD) | 2510 (TLD) | | | | | | | | | | | | | |
| Car dimension (mm) | Width (CW) | 1400 | | 1100 | | 1600 | | 1200 | | 2000 | | 1400 | | 2000 | | 2100 | | |
| | Depth (CD) | 1500 | | 2100 | | 1400 | | 2300 | | 1400 | | 2400 | | 1700 | | 1600 | | |
| | Height (CH) | 2200 to 3200 (in 100 mm increments) | | | | | | | | | | | | | | | | |
| Door dimension (mm) | Opening height (OPH) | 2000 / 2100 / 2200 / 2300 / 2400 | 2100 / 2200 / 2300 / 2400 | 2000 / 2100 / 2200 / 2300 / 2400 | 2100 / 2200 / 2300 / 2400 | 2000 / 2100 / 2200 / 2300 / 2400 | 2100 / 2200 / 2300 / 2400 | 2000 / 2100 / 2200 / 2300 / 2400 | 2100 / 2200 / 2300 / 2400 | 2000 / 2100 / 2200 / 2300 / 2400 | 2100 / 2200 / 2300 / 2400 | 2000 / 2100 / 2200 / 2300 / 2400 | 2100 / 2200 / 2300 / 2400 | 2000 / 2100 / 2200 / 2300 / 2400 | 2100 / 2200 / 2300 / 2400 | 2000 / 2100 / 2200 / 2300 / 2400 | 2100 / 2200 / 2300 / 2400 | |
| | Opening width (OP) | Telescopic (TLD) | 900 | 900 | 800 / 900 / 1000 | | - | | 1000 / 1100 | | - | | 1300 | | - | | - | |
| | | Center 2 panels (CLD) | | | 800 / 900 | | 900 / 1000 / 1100 | | - | | 1100 | | - | | 1100 | | 1100 | |
| Center 4 panels (CLD2) | | - | - | - | | - | | - | | - | | - | | - | | - | | |
| Top of car balustrade (mm) | | 1100 | | | | | | | | | | | | | | | | |
| Standard overhead (for CH = 2400) (mm) | | 5340 | | 5340 | | | | 5360 | | 5360 | | 5360 | | 5360 | | 5360 | | |
| Standard pit (mm) | | 2000 | 2410 | 2000 | 2410 | 2000 | 2410 | 2080 | 2450 | 2080 | 2450 | 2080 | 2450 | 2080 | 2450 | 2080 | 2450 | |
| Maximum number of stops | | 50 / 32 (Flat COP) | | | | | | | | | | | | | | | | |
| Maximum rise (m) | | 150 | | | | | | | | | | | | | | | | |
| Cars in group | | Up to 8 | | | | | | | | | | | | | | | | |
| Standard power (V) | | 380 - 400 - 415 - 440 - 460 | | | | | | | | | | | | | | | | |
| Frequency (Hz) | | 50 - 60 | | | | | | | | | | | | | | | | |

EN81-20 & 50 Compliant dimensions. Please contact your local sales representative depending on configurations for detailed specifications.

| 900 | | 1000 | | | | 1275 | | | | 1600 | | | | | |
|-------------------------------------|--------------------|---------------------|-------------------|-------------------|-------------------|-------------------|-------------------|---------|------|---------|------|---------|------|---------|------|
| 12 | | 13 | | | | 17 | | | | 21 | | | | | |
| Wide | | Deep | | Wide | | Deep | | Wide | | Deep | | Wide | | | |
| 1 | | | | | | | | | | | | | | | |
| 3.5 | | | | | | | | | | | | | | | |
| Without | With | Without | With | Without | With | Without | With | Without | With | Without | With | Without | With | Without | With |
| 2210 (CLD900) | 2300 (CLD900) | 1960 (CLD800) | 2050 (CLD800) | 2330 (CLD900) | 2430 (CLD900) | 1930 (TLD1000) | 2030 (TLD1000) | 2730 | 2830 | 2310 | 2310 | 2730 | 2830 | 2830 | 2930 |
| 2130 (TLD900) | 2230 (TLD900) | 2060 (CLD900) | 2150 (CLD900) | 2410 (CLD1000) | 2500 (CLD1000) | 2010 (TLD1100) | 2030 (TLD1100) | | | | | | | | |
| | | 1830 (TLD900) | 1930 (TLD900) | 2510 (CLD1100) | 2600 (CLD1100) | | | | | | | | | | |
| | | 1860 (TLD1000) | 1930 (TLD1000) | | | | | | | | | | | | |
| 1800 (CLD) | 2060 (CLD) | 2400 (CLD) | 2460 (CLD) | 1750 (CLD) | 2010 (CLD) | 2690 (TLD) | | 1750 | 2010 | 2790 | 2790 | 2000 | 2260 | 1900 | 2110 |
| 1890 (TLD) | 2110 (TLD) | 2490 (TLD) | 2510 (TLD) | | | | | | | | | | | | |
| 1400 | | 1100 | | 1600 | | 1200 | | 2000 | | 1400 | | 2000 | | 2100 | |
| 1500 | | 2100 | | 1400 | | 2300 | | 1400 | | 2400 | | 1700 | | 1600 | |
| 2200 to 3200 (in 100 mm increments) | | | | | | | | | | | | | | | |
| 2100 / 2200 / 2300 / 2400 | | | | | | | | | | | | | | | |
| 900 | 800 900 1000 | - | - | 1000 1100 | - | 1300 | - | - | - | - | - | - | - | - | - |
| | 800 900 | 900 1000 1100 | - | - | 1100 | - | 1100 | - | - | - | - | - | - | - | - |
| - | - | - | - | - | - | - | - | - | - | - | - | - | - | - | - |
| 1100 | | | | | | | | | | | | | | | |
| 5400 | | | | | | | | 5430 | | | | | | | |
| 2550 | 2700 | 2550 | 2780 | 2630 | | | | | | | | | | | |
| 50 / 32 (Flat COP) | | | | | | | | | | | | | | | |
| 150 | | | | | | | | | | | | | | | |
| Up to 8 | | | | | | | | | | | | | | | |
| 380 - 400 - 415 - 440 - 460 | | | | | | | | | | | | | | | |
| 50 - 60 | | | | | | | | | | | | | | | |

ELEVATION

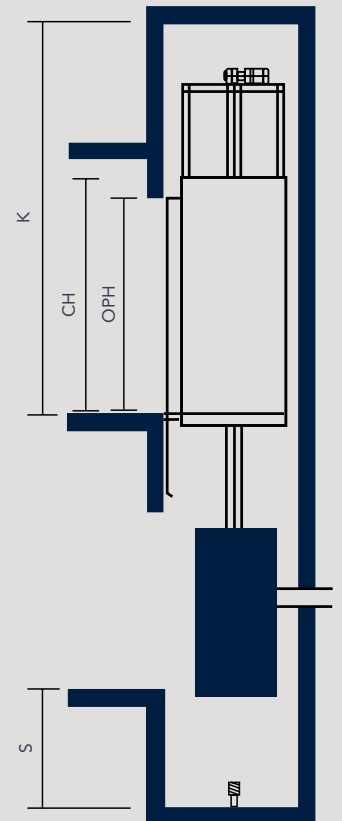

One telescoping door entrance

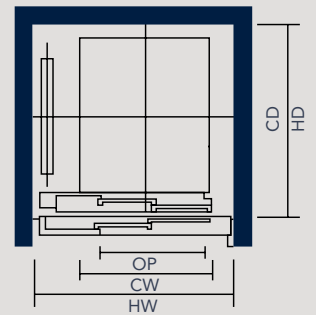

HOISTWAY PLAN

Gen2 Machine room specifications (1 - 2.5 m/s)

FOR BOTH REAR COUNTERWEIGHT AND SIDE COUNTERWEIGHT

| Duty load (kg) | Speed (m/s) | Pit Depth S Minimum (mm) | Overhead K Minimum (mm) | | Minimum number of stops | Maximum rise (m) | Cars in a group |
|----------------|-------------|--------------------------|-------------------------|---------|-------------------------|------------------|-----------------|
| | | | EN81-1 | EN81-20 | | | |
| 630-1000 | 1 | 1157 | 3759 | 3959 | 16 | 50 | Up to 8 |
| | 1.5 | 1224 | 3906 | 4106 | 36 | 75 | |
| | 1.6 | 1224 | 3917 | 4117 | 36 | 90 | |
| | 1.75 | 1259 | 3970 | 4170 | 36 | 100 | |
| | 2 | 1324 | 4067 | 4267 | 45 | 125 | |
| | 2.5 | 1555 | 4306 | 4506 | 50 | 140 | |
| 1150-1600 | 1 | 1157 | 3759 | 3959 | 16 | 50 | |
| | 1.5 | 1222 | 3904 | 4104 | 36 | 75 | |
| | 1.6 | 1222 | 3915 | 4115 | 36 | 90 | |
| | 1.75 | 1268 | 3979 | 4179 | 36 | 100 | |
| | 2 | 1328 | 4071 | 4271 | 45 | 125 | |
| | 2.5 | 1583 | 4306 | 4506 | 50 | 140 | |
| 1800-2000 | 1 | 1220 | 3800 | 4000 | 16 | 50 | |
| | 1.5 | 1320 | 3950 | 4150 | 36 | 75 | |
| | 1.6 | 1320 | 3950 | 4150 | 36 | 90 | |
| | 1.75 | 1370 | 4000 | 4200 | 36 | 100 | |
| | 2 | 1425 | 4100 | 4300 | 45 | 120 | |
| | 2.5 | 1710 | 4350 | 4550 | 50 | 120 | |

FOR SIDE COUNTERWEIGHT ONLY

| Duty load (kg) | Speed (m/s) | Car dimension (mm) | | Door dimension (mm) | | Hoistway dimension (mm) | |
|----------------|-------------|--------------------|------|---------------------|--------|-------------------------|------|
| | | CW | CD | Opening (OP) | Door | HW | HD |
| 630 | 1-2.5 | 1400 | 1100 | 800 | Center | 2150 | 1600 |
| 680 | | 1400 | 1200 | 800 | | 2150 | 1600 |
| 800 | | 1400 | 1350 | 800 | | 2150 | 1750 |
| 900 | | 1600 | 1350 | 900 | | 2350 | 1750 |
| 1000 | | 1600 | 1400 | 900 | | 2350 | 1900 |
| 1150 | | 1800 | 1450 | 1000 | | 2550 | 1850 |
| 1350 | | 2000 | 1500 | 1000 | | 2750 | 1900 |
| 1600 | | 2000 | 1700 | 1100 | | 2750 | 2100 |
| 1800 | | 1900 | 2000 | 1100 | | 2570 | 2330 |
| 2000 | | 2000 | 2000 | 1100 | | 2670 | 2330 |

FOR REAR COUNTERWEIGHT ONLY

| Duty load (kg) | Speed (m/s) | Car dimension (mm) | | Door dimension (mm) | | Hoistway dimension (mm) | |
|----------------|-------------|--------------------|------|---------------------|--------|-------------------------|------|
| | | CW | CD | Opening (OP) | Door | HW | HD |
| 630 | 1-2.5 | 1400 | 1100 | 800 | Center | 2000 | 1700 |
| 680 | | 1400 | 1200 | 800 | | 2000 | 1800 |
| 800 | | 1400 | 1350 | 800 | | 2000 | 1950 |
| 900 | | 1600 | 1350 | 900 | | 2200 | 1950 |
| 1000 | | 1600 | 1400 | 900 | | 2200 | 2000 |
| 1150 | | 1800 | 1450 | 1000 | | 2400 | 2100 |
| 1350 | | 2000 | 1500 | 1000 | | 2500 | 2150 |
| 1600 | | 2000 | 1700 | 1100 | | 2500 | 2350 |

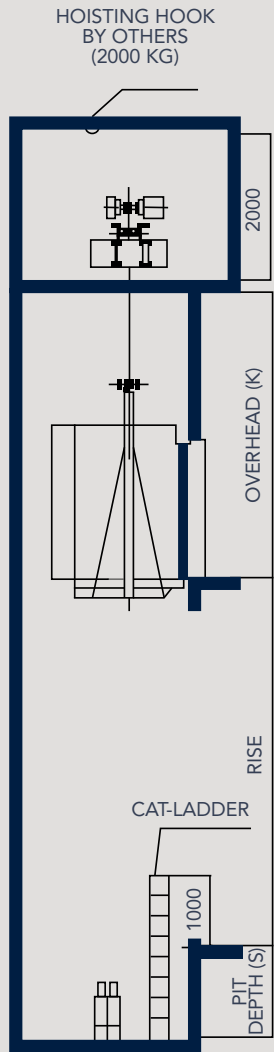

ELEVATION

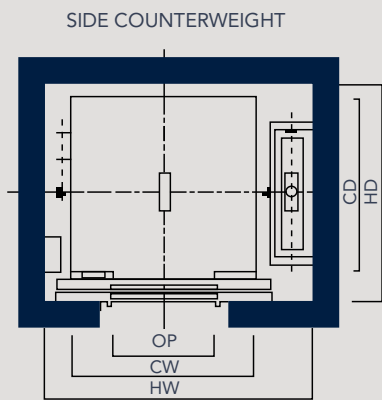

HOISTWAY PLAN

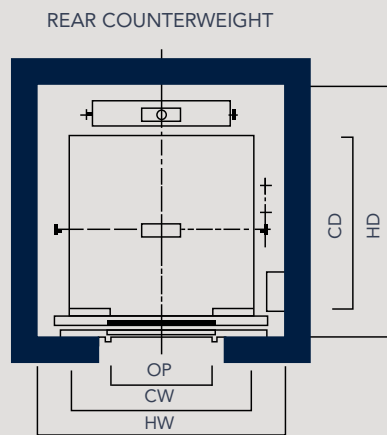

HOISTWAY PLAN

Solutions in motion

Our Gen2 elevators blend convenience, style and performance to deliver a new passenger experience that adds value to any residential, commercial, hospitality, medical or industrial building.

OUR FAMILY OF ELEVATORS AND ESCALATORS



ARISE ELEVATORS

Our Arise elevators focus on delivering an efficient and high-quality solution for your customers, tenants or passengers that changes how they experience your building.



LINK™ ESCALATORS & MOVING WALKS

Ultimately safe, incredibly reliable and designed to integrate seamlessly with your building, our escalators and moving walks are engineered to be whisper quiet and smooth.



SKYRISE® ELEVATORS

Otis teams on site coordinate with contractors and builders, monitor specialized safety reviews and efficient installation as well as smooth handover when the project is complete.





OUR BEST-SELLING ELEVATOR

Some of the world's most iconic buildings are home to Gen2.

To learn more about our comprehensive family of products and services, visit www.otis.com.

Built on a legacy of innovation, Otis was founded in 1853 after Elisha Otis invented the elevator safety brake, giving rise to the modern city, transforming how people live and work, and revolutionizing architecture itself. Today, we are the world's leading company for elevator and escalator manufacturing, installation and service. We move 2 billion people a day and maintain more than 2 million customer units worldwide, the industry's largest maintenance portfolio. We can be found in many of the world's most recognizable buildings, as well as the busiest transportation hubs and retail centers – we are everywhere people are on the move. Headquartered in Connecticut, USA, Otis is 69,000 people strong, including 40,000 field professionals, all committed to meeting the diverse needs of our customers and passengers in more than 200 countries and territories worldwide. To learn more, visit www.otis.com and follow us on LinkedIn, Instagram, Facebook and Twitter @OtisElevatorCo.